

Document Reference:-	NSP/004/124	Document Type:-	Code of Practice				
Version:-	2.0	Date of Issue:-	November 2023	Page	1	of	26

NSP/004/124 – Code of Practice for the Installation of Optical Ground Wire (OPGW) on Tower Lines

1. Purpose

The purpose of this document is to provide guidance on the installation of Fibre Optic OPGW (Optical Ground Wire) on tower lines located on the Northern Powergrid distribution system.

This document supersedes the following documents, all copies of which should be destroyed;

Document Reference	Document Title	Version	Published Date
NSP/004/124	Code of Practice for the Installation of Optical Ground Wire (OPGW) on Tower Lines	1.0	Jan 2020

2. Scope

This code of practice applies to the replacement of standard Horse or Keziah earth wires used on 66-132 kV Tower lines with a composite fibre optic overhead ground wire for use on the distribution system of Northern Powergrid.

Document Reference:-	NSP/004/124	Document Type:-	Code of Practice				
Version:-	2.0	Date of Issue:-	November 2023	Page	2	of	26

2.1. Table of Contents

1. Purpose	1
2. Scope	1
2.1. Table of Contents	2
3. Technical Specification	4
3.1. Precautions.....	4
3.2. OPGW Construction Details.	4
3.3. Route Design Considerations	4
3.3.1. Wayleaves	4
3.4. OPGW Installation	5
3.4.1. Stringing Method	5
3.4.2. Stringing Procedures	6
3.4.3. Cable Pay-off	6
3.4.4. Tensioner.....	6
3.4.5. Puller	6
3.4.6. Stringing Tension.....	7
3.4.7. Cable Stringing	7
3.5. Sagging Methods.....	7
3.6. Stringing Blocks or Sheaves.....	8
3.7. Anti- Rotational Devices.....	8
3.8. Tower Arrangement Drawings	9
3.9. Conductor Cutting	9
3.10. Support Fittings.....	9
3.10.1. Assembly Details for Helical Deadends at Tension towers	10
3.10.2. Assembly Details for Armour Rod Line Guards	10
3.10.3. Assembly Details for Suspension sets	11
3.10.4. Assembly Details for Stockbridge Dampers	11
3.11. Splice Points	12
3.12. Interface with Underground Fibre Systems	13
3.13. Fibre optic Testing Requirements	13
3.13.1. Testing prior to installation	13
3.13.2. Testing after cabling.....	13
3.13.3. End to End testing following completion of terminations	13
3.13.4. As Built Records.....	14
3.14. Accessories and fittings.....	15
4. References.....	16

Document Reference:-	NSP/004/124	Document Type:-	Code of Practice				
Version:-	2.0	Date of Issue:-	November 2023	Page	3	of	26

4.1.	External Documentation	16
4.2.	Internal Documentation	16
4.3.	Amendments from Previous Version	16
5.	Definitions	17
6.	Authority for Issue	18
6.1.	CDS Assurance	18
6.2.	Author	18
6.3.	Technical Assurance	18
6.4.	Authorisation.....	18
Appendix 1 – OPGW Section Structure – (Tails down to Splice Box)		19
Appendix 2 – OPGW Section Splice Arrangement.....		20
Appendix 3 – OPGW Section Structure – (Straight Through Arrangement).....		21
Appendix 4 – OPGW Intermediate Structure – (Suspension Arrangement)		22
Appendix 5 – OPGW Terminal Structure.....		23
Appendix 6 – OPGW Terminal Structure with Underground Splice Connection		24
Appendix 7 – OPGW Tee-off Splice Arrangement		25
Appendix 8 – Typical Tower Cleat.....		26

Document Reference:-	NSP/004/124	Document Type:-	Code of Practice				
Version:-	2.0	Date of Issue:-	November 2023	Page	4	of	26

3. Technical Specification

OPGW is an optical fibre ground wire that provides the functionality of a standard earthwire without any change in the overall electrical or mechanical characteristics of a standard earthwire whilst also containing optical fibres. The conductive part of the cable serves to bond adjacent towers to earth and shield the current carrying conductors from lightning strikes whilst the optical fibres can be used to carry high speed, high bandwidth telecommunications and protection signals.

The optical fibres are installed inside stainless steel buffer tubes which are supported and protected by layers of aluminium clad steel and aluminium alloy strands to form a composite conductor as such the expected design life of OPGW shall be similar to that of traditional ACSR earthwire.

OPGW shall be supplied complete with all necessary support fittings and splice enclosures to enable the system to be installed end to end. OPGW can be installed using the basic stringing methods currently employed for overhead earthwires, with minor variations to safeguard the integrity of the fibre. Further details on installation techniques and fittings used to support and terminate the OPGW are contained within this code of practice.

3.1. Precautions

Care must be taken to avoid damaging the OPGW during handling and stringing operations. Avoid sharp bends to the conductor and take precautions to prevent crushing the OPGW during placement. The transmission quality of the optical fibres can potentially be degraded if the OPGW is subjected to excessive pulling tensions or excessively small bend diameters hence it is important to observe the recommended values for Maximum Stringing Tensions and Minimum Bend Radius.

3.2. OPGW Construction Details.

For details on the fibre count and construction requirements of OPGW, reference shall be made to NPS/002/024 “Technical Specification for Fibre Optic Cables, Wrap, OPGW and ADSS”

3.3. Route Design Considerations

The following information shall be provided to the OPGW system installers or their sub-contractors designing the OPGW system in advance of any new installation project to ensure that the optimum design is provided.

Line schedules, route maps, tower design drawings, any required splice locations e.g. adjacent to tee –off or underground connection points, together with details of all road/rail and plus power line crossings.

This information will then be used to confirm the optimum section/drum lengths, those points where access for drums trailers and winches will be required, section structures to be run through and those with splice break points etc.

Additionally the design company/installer shall consider the line outage requirements for the project taking into account the ability to work within the “SMCC Guidance Notes – Earthwire replacement with one circuit alive on 132kV double Circuit Tower lines” or the need for Double Circuit outages where adequate clearances or working methods cannot be achieved.

3.3.1. Wayleaves

Installing the OPGW requires access to every support for personnel and equipment (although the majority of supports will only require climbing access). Providing the fibre optic cable is only being used for internal communications or protection purposes it is not normally necessary to re-negotiate new wayleave agreements.

Document Reference:-	NSP/004/124	Document Type:-	Code of Practice				
Version:-	2.0	Date of Issue:-	November 2023	Page	5	of	26

3.4. OPGW Installation

Drum Preparation Prior to Beginning a Pull

The OPGW manufacturers will normally despatch the conductor drums with the inner tail securely connected to the outside of the drum flange. This connection should be loosened, but not removed, prior to stringing. This allows the inner layers of conductor to adjust themselves to the varying tensions seen during installation. As the conductor makes these adjustments, the inner tail may lengthen, or “grow,” requiring periodic attention to ensure that the conductor continues to be in a state where it can “grow” out. See also testing of the OPGW prior to the installation works as detailed in clause 3.12.1

3.4.1. Stringing Method

To prevent damages, the OPGW must be installed using the controlled tension stringing method to keep it clear of the ground and obstacles that could damage the conductor or away from adjacent live circuits. Use of this method allows the use of ordinary stringing equipment as if installing standard overhead earthwire conductor.

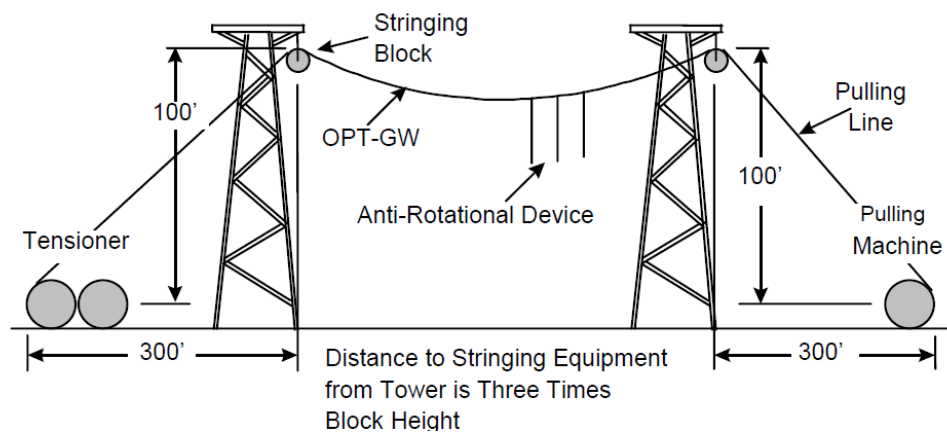

The sketch above shows a typical stringing equipment setup designed to ensure that the bending radius of the fibre is not exceeded during installation works. In general it involves the tensioner and pulling machines being located a minimum of 3 x the height of stringing blocks from ground level in front of and behind the tower of the section of line being conductored.

There is one primary difference between installing OPGW and conventional overhead earthwires, and that is that OPGW can only be jointed or spliced at predetermined towers on each end of a stringing section removing the flexibility that exists with standard earthwire. After installing conductor deadends, the free ends of the OPGW are trained down the towers to the ground for splicing. The length of the free conductor should be at least the tower height, plus an additional (20 meters) to accommodate the splicing. After stringing, this conductor length is typically coiled and temporarily stored at the tower above the ACD’s until the splicing occurs.

The OPGW will also use special attachment hardware, including deadends; suspension clamps, and wire fittings such as grounding clamps. The hardware is designed to provide the necessary holding strengths and prevent deformation of the OPGW which could potentially damage the optical fibres.

The temperature ranges for OPGW conductor is declared as follows: Storage: -50°C to + 85°C; Installation: -40 °C to +85 °C; Operation: -40 °C to + 85 °C

Document Reference:-	NSP/004/124	Document Type:-	Code of Practice				
Version:-	2.0	Date of Issue:-	November 2023	Page	6	of	26

3.4.2. Stringing Procedures

Pulling lines are normally nylon ropes rated to withstand the required stringing tensions. The pulling line should have the same direction lay as the OPGW to help resist the tendency to rotate under stringing load.

If an existing overhead earthwire is to be removed, it can potentially be used as a pulling line for the OPGW providing it has been inspected for suitability prior to the works. This inspection will normally involve both a visual inspection of the wire throughout its length looking for signs of bird caging or broken strands and the selected application of the Cormon tester in representative spans that make up the route. If there is any concern about the existing earth wire’s ability to withstand the stringing tensions, it should be pulled out and replaced with a pulling line.

3.4.3. Cable Pay-off

Conductor pay-off can be a drum stand or a movable drum carrier. In any case it must be equipped with a suitable brake to prevent the drum from carrying on turning when the stringing stops. This would cause the cable layers slackening on the drum. The pay-off should be positioned not less than 5m behind the tensioner. It is not permitted to do tension stringing directly from the drum without using a tensioner.

3.4.4. Tensioner

The bullwheel sheave diameter shall either be greater than 70 times the cable diameter or 1200 mm whichever is smaller. The wheels must be in such condition that they do not have any burrs or cavities which may damage the conductor. The running-grooves must be adapted in size to the cable diameter; ideally they will be coated with a neoprene or similar material.

The tensioner must be able to assure constant tension and allow a steady slow down at different stringing speeds without the effect of cable run after. Tensioning should be readily controllable and capable of maintaining constant and even operation. There should be a minimum of 6 turns to anchor the cable. To prevent the conductor from birdcaging the correct orientation for entry and exit of the cable must be respected. For standard right hand lay (Z), the cable must enter the brake on the left and exit on the right.

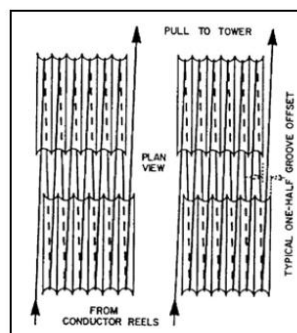

3.4.5. Puller

The puller shall preferably be a bullwheel puller with integrated or separate drum winder. The speed must be infinitely variable and allow a smooth pull of the cable without jerking or bouncing. The puller must be equipped with a tension control system with an adjustable overtension switch. The stringing tension shall be recorded during the whole installation monitor the maximum tensions employed. Before stringing, the puller calibration details of the tension control system shall be checked.

The drum shall be placed directly in line with the tensioner. The distance from the drum to the tensioner should be at least 7.5 meters. The OPGW shall not be permitted to scrape the drum flanges while being pulled.

The tensioner and puller should be positioned at a minimum ratio of 3:1 to the stringing block on the first structure adjacent to the equipment. The tensioner should be placed in line with the first two structures (or first span) of the pull. Likewise, the puller should be placed in line with the last two structures (or last

Document Reference:-	NSP/004/124	Document Type:-	Code of Practice				
Version:-	2.0	Date of Issue:-	November 2023	Page	7	of	26

span) of the pull. Doing so minimizes the line angle change seen by the conductor during the installation process.

3.4.6. Stringing Tension

During cable stringing the maximum installation tension, which is given in the manufacturer’s data sheet, shall not be exceeded. This value should be understood as an absolute maximum for unforeseen disturbances during the stringing process or for installations with very difficult conditions (e.g. mountains, valley crossing etc.). The regular installation force should not exceed 20% of the cable's rated tensile strength. The stringing tension must be controlled by a puller with automatic switch off at the limit tension.

3.4.7. Cable Stringing

The cable is supplied with band clamps at both ends. These clamps must not be removed before the stringing process is finished. The pulling rope should have a low twist effect. In case of replacement, the old conductor can be used as pulling rope; if it is suitable regarding size and condition (see section 3.4.2).

The pulling rope should be attached to the cable by a swivel link with the help of a of wire mesh grip



The installation equipment i.e. the puller and tensioner should be placed in line with the two first towers (or within a maximum offset of 10°). The sheaves at the running-in point and at the exit point of the line should be arranged in such a way that bird-caging of the cable is prevented. If there are signs of bird-caging the stringing should be interrupted and the stringing arrangement corrected.

During stringing special attention must be paid to the swivel and wire mesh grip running through the sheaves and lattice towers. Special attention must be paid during insertion of the cable into the lattice tower for joint box installation, to prevent damage or bird-caging.

For cable splicing a certain excess length of tubes and fibres is necessary which will be placed in the fibre joint box. Cable splicing generally takes place at ground level in the rear of a van, to facilitate this process the required excess conductor length shall be assumed to be 20m.

le the conductor length in a section of line needs to be the section length of the line in question plus the height of both section towers at each end of the section of line plus 2 x 20m.

3.5. Sagging Methods

The methods and procedures for sagging the OPGW are the same as those for normal overhead earthwires. For determining sags, the installer should use the sag-tension design information provided by Northern Powergrid or the OPGW Supplier.

A temporary grip is installed on the OPGW for tensioning. The grip must be designed to hold the OPGW without damage, and in particular not pinch the conductor or crush the stainless steel tube within the conductor. Certain types of formed guy grips can also be used successfully, but their use in stringing applications should be checked with the grip’s manufacturer.

Document Reference:-	NSP/004/124	Document Type:-	Code of Practice				
Version:-	2.0	Date of Issue:-	November 2023	Page	8	of	26

3.6. Stringing Blocks or Sheaves

Diameter of Stringing Blocks (Bottom of groove)		
Initial and terminal points of the line (deflection angle $\leq 120^\circ$)	$\geq 800\text{mm}$	
At Section Towers	$\geq 600\text{mm}$	
At Suspension Towers	$\geq 450\text{mm}$	

Generally it is recommended that the sheave diameters of stringing blocks should be as big as possible to limit the load for the cable. Due to the use of Al Alloy in the construction of the outer layers of the OPGW, then the running blocks may be metallic or lined with neoprene coated grooves.

Note

All re-conductoring work shall be carried out in accordance with ENA G67 "Safety in conductor stringing on Overhead transmission Lines". Where earthwire replacement work is required to be carried out under single circuit live working conditions, it shall be in accordance with the SMCC 006 "Notes of guidance on Earth Wire replacement with one circuit live on 132kV double circuit tower lines" in particular the requirement for all earthwires to be inspected with a cormon tester before been considered for this replacement methodology.

In either case it must be ensured that the sheave grooves do not damage the OPGW with grooves adapted to the OPGW, i.e. no smaller than 0.55 times the OPGW diameter. The groove profile and radius should be wide enough to allow passage of swivels and wire mesh grips. If an old conductor is used as a pulling rope, then the size of rope joints must also be taken into consideration. For that reason, the sides of the grooves should open in an angle between 15° and 20° .

The linings should be in good condition and adhering to the block. Minor rough areas can be sanded out to ensure the lining is smooth. Uplift rollers (which attach to the installation sheave wheel) or hold-down blocks (which are separate blocks) need to be placed where uplift of the pulling line is likely to occur (due to its higher tension/weight ratio than the conductor). This will typically occur going up inclines or at a low point in a section. These devices should also have a break away feature in the event of fouling or incorrect installation.

3.7. Anti- Rotational Devices

Anti-Rotational Devices shall always be used when installing OPGW to prevent the OPGW from twisting while being pulled. If the anti-rotational device is not preventing the conductor rotation or if the anti-rotational device is wrapping around the OPGW, a stiffer or heavier device is required. The weight and length of the ARD will depend upon the construction of the optical earthwire. The anti-rotational device attaches to the OPGW with a Kellum type grip. The grip must be appropriately sized for the OPGW diameter and pulling tensions.

Document Reference:-	NSP/004/124	Document Type:-	Code of Practice				
Version:-	2.0	Date of Issue:-	November 2023	Page	9	of	26

3.8. Tower Arrangement Drawings

Tower Arrangement	Northern Powergrid Arrangement Drawing	See Appendix “ “
Section Structure – Spliced Section (Tower Top)	1091010800 Sht 1	1
Section Structure – Spliced Section (Splice Arrangement)	1091010800 Sht 2	2
Section Structure – Continuous Section (Tower Top)	1091010801 sht 1	3
Suspension Structure	1091010802 sht 1	4
Terminal Structure – (Tower Top)	1091010803 sht 1	5
Terminal Structure – Underground Splice Connection	1091010803 sht 2	6
Section Structure – Spliced Section (Tee off Splice)	1091010800 Sht 3	7
Tower Clamps – Detail drawing	1091010804 sht1	8

3.9. Conductor Cutting

Do not cut the OPGW with ratchet cutters, or other types of tools that could crush the fibre tube. The use of a hacksaw will ensure the fibre optic is free to move within the stainless Steel Tube.

3.10. Support Fittings

Deadends are installed on OPGW spans that terminate at splicing towers or terminal towers. Deadends are also used at angle structures when the angles are too great to use suspension clamps. Suspension clamps are normally used at the remaining towers.









OPGW is installed using stringing blocks. If left in the stringing blocks for extended periods of time, the potential for motion induced damage (conductor hammer) increases. Also, the creep of the conductor is affected due to the change in the initial condition on the conductor. In order to diminish the probability of motion induced damages and creep rate change, then tensioning and anchoring of the OPGW to the structure and removal of the stringing blocks shall be completed no later than 48 hours after pulling the conductor in.

There are several ways to lift the OPGW from the stringing blocks in order to install the hardware. Basically, come-along clamps are attached on both sides of the block and a coffin hoist is placed over the tower arm. The hooks of the coffin hoist are attached to the come-along clamp and jacked up to form a small loop in the OPGW. The block can then be removed and the armour rods can be placed on the OPGW then attached to the structure. Alternately, certain types of preformed wire grips can be used instead of come-along clamps.



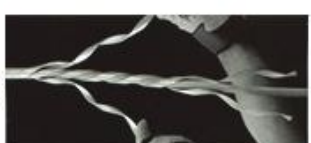



If vibration dampers are required for the span, these should be placed on the OPGW immediately after clipping in. Dampers may not be required at every structure; their locations will be specified by Northern Powergrid or the conductor supplier. Only vibration dampers specific to OPGW conductor which have been installed and tested in accordance with ENA 43-126 shall be used.

Document Reference:- NSP/004/124		Document Type:- Code of Practice	
Version:- 2.0	Date of Issue:- November 2023	Page 10	of 26

3.10.1. Assembly Details for Helical Deadends at Tension towers





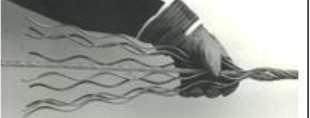
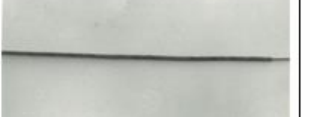



 <p>① TENSION SET FOR OPGW CABLE</p>	 <p>② BEGIN THE INSTALLATION OF THE PROTECTION RODS OVER THE IDENTIFICATION CENTRAL MARK ONE PITCH AT EACH SIDE. TAKE IN MIND THE TOTAL LENGTH OF THE STRING. A DRAWING.</p>	 <p>③ ASSEMBLY ALL THE SUBSETS IN THE SAME WAY OF PICTURE 2.</p>
 <p>④ ALTERNATIVELY ASSEMBLE ONE BY ONE SUBSET AT BOTH SIDES.</p>	 <p>⑤ LEAVING WITHOUT ASSEMBLE THE LAST TWO PITCH OF THE SUBSET TILL THE END.</p>	 <p>⑥ TO FINALIZING THE ASSEMBLY OF THE SUBSETS DIVIDE THEM AND CARRY OUT BY HAND.</p>
 <p>⑦ PUT THE DEAD END OVER THE PROTECTION RODS TAKE IN MIND AS IN THE SECOND STEP THE TOTAL LENGTH OF THE STRING.</p>	 <p>⑧ ASSEMBLE BOTH LEGS OF DEAD END TILL THE LAST TWO PITCHES. THE HOLES BETWEEN LEG MUST BE SIMILAR.</p>	 <p>⑨ TO FINALIZE THE ASSEMBLY SEPARATE THE RODS TO FACILITATE THE ASSEMBLY.</p>

3.10.2. Assembly Details for Armour Rod Line Guards

 <p>① THE ROD MUST BE SUITABLE TO THE CABLE AND TO THE LAY DIRECTION OF CABLE.</p>	 <p>② IT IS MARKED ON THE CABLE THE INSTALLATION POINT WHERE THE RODS HAVE TO BE ASSEMBLED.</p>	 <p>③ THE CENTRAL MARK OF THE ROD HAS TO BE PUT ON THE CABLE MARK. ASSEMBLE ONE PITCH AT BOTH SIDE OF THE MARK.</p>
 <p>④ ASSEMBLE ALL THE RODS ONE PITCH AT BOTH SIDES OF THE INSTALLATION MARK.</p>	 <p>⑤ NOW ALL THE RODS ARE ASSEMBLED AT THE SAME TIME AT EACH SIDE OF THE MARK, TURNING AT THE LAY DIRECTION OF THE RODS.</p>	 <p>⑥ THE ENDS COULD BE ASSEMBLED IN THE SAME WAY, TURNING THE RODS TILL THE END.</p>
 <p>⑦ IN A BIGGER ROD DIAMETER IT CAN BE ASSEMBLED ONE BY ONE.</p>	 <p>⑧ FINISH THE ASSEMBLY IN THE OTHER SIDE IN THE SAME WAY STEPS 6^o-7^o.</p>	 <p>⑨ ASSEMBLY FINISHED.</p>

Document Reference:- NSP/004/124		Document Type:- Code of Practice	
Version:- 2.0	Date of Issue:- November 2023	Page	11 of 26

3.10.3. Assembly Details for Suspension sets

 <p>1 PARTS OF THE SUSPENSION SET.</p>	 <p>2 MARKING THE CENTRAL POINT OF SUSPENSION OVER THE CABLE, PUT THE NEOPRENE INSERT IN SUCH WAY, THAT THE JOINT LINE OF BOTH HALVES MUST STAY IN HORIZONTAL PLANE.</p>	 <p>3 IN THE POSITION OF THE PICTURE, FIXING WITH THE RIBBON THE INSERTS.</p>
 <p>4 PUT THE IDENTIFICATION CENTER MARK ON THE CENTER OF THE INSERT, ASSEMBLE ONE OR TWO PITCH AT BOTH SIDES.</p>	 <p>5 IN THE SAME WAY OF POINT NUMBER 4^o DISTRIBUTING IN UNIFORM WAY THE HOLES ON THE INSERT.</p>	 <p>6 TO FINALIZING THE ASSEMBLE OF THE RODS ALL TOGETHER.</p>
 <p>7 PUT THE ALUMINIUM BODY OVER THE INSERT PLUS RODS AND AFTER THAT THE ALUM ALLOY SUPPORT.</p>	 <p>8 ASSEMBLE THE BOLT, SPRING WASHER, NUT AND THE SECURITY PIN.</p>	 <p>9 MOUNTED CLAMP.</p>

Note – OPGW shall always be supported at suspension towers through the use of AGS (Armour Grip Suspension Units).

3.10.4. Assembly Details for Stockbridge Dampers

Note – the installation location for the vibration dampers shall be as specified by the fitting supplier following a review of the vibration requirement's for each specific section of line.

 <p>1 TENSION SET FOR OPGW CABLE, WHERE THE DAMPER IS GOING TO BE INSTALLED.</p>	 <p>2 DAMPER STOCKBRIDGE, THE CHARACTERISTICS OF THE CABLE (DIAMETER, COMPOSITION, ETC) AND THE LINE (TENSILE LOAD, TERRAIN ETC) MUST BE THE SUITABLE FOR THE DAMPER RESPONSE</p>	 <p>3 THE OUTER DIAMETER OF THE CABLE PLUS ARMOR RODS, MUST BE INSIDE THE DIAMETER RANGE OF THE CLAMP.</p>
 <p>4 TO FIX ON THE INSTALLATION POINT (CALCULATED PREVIOUSLY), THE MATCHING BETWEEN THE CABLE AND THE DAMPER CLAMP MUST BE OK.</p>	 <p>5 THE MAXIMUM TIGHTENING TORQUE WILL BE FIXED BY THE MANUFACTURER. THE DYNAMOMETRIC WRENCH WILL BE SUITABLE FOR THIS TORQUE.</p>	 <p>6 WHEN THE WRENCH REACHES THE TORQUE, THE DAMPER WILL BE INSTALLED.</p>
 <p>7 SAME WAY WITH THE SUSPENSION SET.</p>	 <p>8 INSTALLED DAMPER.</p>	

Document Reference:-	NSP/004/124	Document Type:-	Code of Practice				
Version:-	2.0	Date of Issue:-	November 2023	Page	12	of	26

3.11. Splice Points

Unlike traditional earthwire installations, OPGW installations aim to minimise the number of splice points by running through section towers, with splices normally occurring at the end of each natural OPGW drum length, typically between 2-6km dependent upon the line route, or at points needed for tee-offs.

After completion of sagging and clipping, the surplus OPGW should be coiled and attached temporarily to the tower. Coils should be approximately 1 to 1.5m in diameter. The coils should be fixed on the tower to prevent any damage to the OPGW prior to splicing.

The exposed ends of the OPGW should be re-sealed to prevent moisture from entering the stainless steel tubes.

The OPGW shall be trained down the tower and to the ground for splicing. Do not cut off any excess length of the OPGW at this time. To facilitate splicing, the OPGW should extend a minimum of 20m beyond the bottom of the tower. The length of OPGW running down the tower should be attached to the structure using tower cleats as detailed on drawing 1091010804 sht1, cleats shall be spaced every 1.8 to 2.4m of running length.

The splice enclosure will typically be installed on the structure leg at a point above the anti-climbing guard and outside of the safe working access distance from the lowest live circuit conductors. In most cases, it will be desirable to store extra conductor on the tower. This will allow the splice box to be removed and lowered to the ground if it is ever necessary. This can be accomplished with a simple loop of OPGW below the splice box or by permanently storing a coil of OPGW higher on the tower in a neat and secure fashion.

Fibre optic jointing shall be carried out using fusion type fibre splices. All splicing shall be carried out in strict accordance with the cable manufacturer's and splicer manufacturer's instructions. The Contractor shall be an experienced, qualified and suitably trained operative in such jointing techniques. The fibre optic jointing shall be undertaken to approved written procedures. The colour code for identifying each fibre is detailed in NPS/002/024 Technical Specification for Fibre Optic Cables and Fibre Wrap. The contractor shall identify each fibre optic cable with a waterproof type of cable marker system before it enters the splice.

Wherever practicable the cable preparation and splicing work shall be carried out either in the back of the splicing vehicle or a suitably covered work area, and not on the support structure. The loose tubes containing the optical fibres shall be cut back to the required length using the appropriate tools. The fibres must have all traces of gel removed from their external surface.

The splice cassette shall, on completion of all splicing, contain nominally 2m but not less than 1.5m of excess fibre. The excess fibre should be securely stored observing the minimum bending radius requirements of the fibre.

The cable central strength member shall be either clamped or directed away from the fibres, and be free to move without obstruction or stressing the fibres.

All fibres shall be fusion spliced (as opposed to mechanical splicing) using a suitable splicing machine. Completed splices shall be protected by a mechanical splice protector. The protected splices shall be placed in the splice organiser (splice trays) within the splice enclosure, which should be sealed upon completion of the work to the manufactures recommended procedures.

Splice Losses – the mean splice loss must be equal to or less than 0.15dB the maximum individual splice loss shall be equal to or less than 0.2dB.

Non-conforming splice losses shall be reworked, the splice will be cut out, the fibres re-cleaved and re-spliced. If the splice still does not conform to the specification, the process must be repeated, up to a maximum of three times. Evidence of these attempts shall be recorded as OTDR traces and presented back to Northern Powergrid with the final test results in the "As built records".

If the attenuation measurement, after the third splice attempt, still does not conform, then the following concessions will apply:

- Mean splice loss <= 0.15dB

Document Reference:- NSP/004/124		Document Type:- Code of Practice	
Version:- 2.0	Date of Issue:- November 2023	Page	13 of 26

- Maximum splice loss must not be greater than 0.3dB

If after splicing the fibre the third time, the concession criteria are not met, an alternative splicing machine must be used. If non-conformance still applies, then this effectively eliminates the splicing techniques as a source of the fault, thus implying the fault lies within the fibre optic cable. This shall then be discussed with the project manager.

3.12. Interface with Underground Fibre Systems

Where OPGW installations interface with underground fibre cable installations, the underground cable shall arrive at the tower base via standard 96mm duct and sub-duct. Transiting from this duct to the joint canister location the fibre cable must be installed within a 32mm standard telecoms sub-duct and from the 96mm duct to a point above the anti-climbing guard. The 32mm sub-duct must in turn be housed inside anaconda galvanised steel piping or capping. At the transit points from the 96mm to the Anaconda, from where the Anaconda ends above the climbing guard and where the 32mm sub-duct interfaces with the joint canister a heat-shrink sleeve must be used to protect the network from water ingress. The Anaconda trunking must be fixed to the tower leg using Anaconda tower leg clamps.

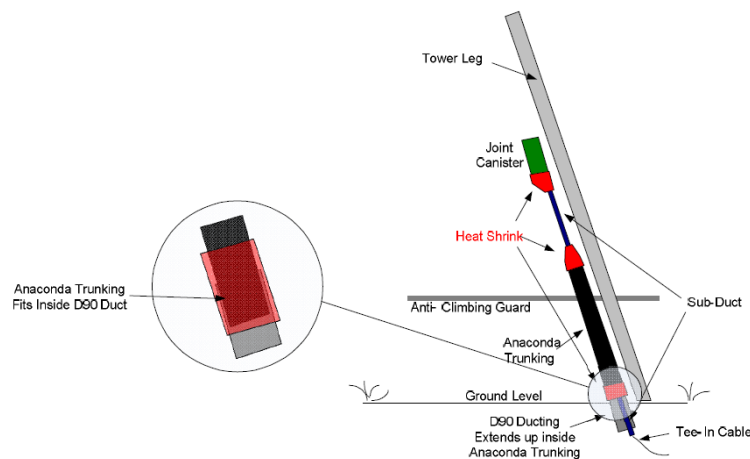

3.13. Fibre optic Testing Requirements

3.13.1. Testing prior to installation

Once the conductor drums have been delivered to the Contractor, tests at 1550nm on each fibre from the conductor end on the outside of the drum shall be taken to ensure that there is no damage prior to installation. Testing at the 1550nm wavelength will show up any microbends from the manufacture process. Northern Powergrid reserves the right to witness these tests. The contractor shall inform Northern Powergrid of any conductor damage discovered before any installation works begin. The test results will be recorded and issued to Northern Powergrid and issued as part of the 'as built' final records.

3.13.2. Testing after cabling

After the OPGW has been installed but before any route splicing occurs, OTDR (Optical time-domain reflectometer) tests shall be carried out on each fibre length in one direction to ensure that there is no damage post-installation. These tests shall be carried out at 1550nm to check for microbends or breaks caused by cabling damage and the results shall be presented to Northern Powergrid and issued as part of the 'as built' final records.

3.13.3. End to End testing following completion of terminations

Northern Powergrid Telecoms or their approved contractors shall carry out termination works of all fibre cables within the Northern Powergrid building. This shall include the internal cabling, mounting of fibre wall boxes, installation of cabinets and ODFs etc. On completion of the installation works the fibre route shall be subjected to bi-directional end to end OTDR and Insertion Loss Measurement (ILM) test at both

Document Reference:-	NSP/004/124	Document Type:-	Code of Practice				
Version:-	2.0	Date of Issue:-	November 2023	Page	14	of	26

1310nm and 1550nm. The results shall be recorded and presented to Northern Powergrid for evaluation and comparison with those provided by the installation contractor.

3.13.4. As Built Records

In addition to the OTDR trace files and insertion loss measurements, the contractor shall provide photographs of each splice enclosure with close ups of the splice trays using a macro camera setting so that the quality of fibre preparation and splicing work is clearly visible. Further photographs of the splice enclosure fitted on the tower (with the tower reference number) shall also be submitted to verify that the close up is of the correct support.

The contractor shall provide record of test results in accordance with 3.13.1 & 3.13.2.

The contractor shall also provide a report including showing the following information as part of the final project record:-

- Details of the optical route
- Date of the tests
- A end identity and B end identity
- Section length in km
- Total number of splices
- The location of each slice and its location in the route i.e. overhead or underground
- Type and location of splice joints including grid ref and OHL tower or pole number.
- Wavelength used for testing
- OTDR – make, model calibration date
- Calculated route attenuation from A end connector to B end connector

Copies of the OTDR traces are to be supplied to Northern Powergrid by the contractor in a digital form.

Optical Power Loss Test

ILM tests are to be carried out on each fibre in the route, in both directions, at 1310nm and 1550nm. All results are to be recorded on the test report.

The test report must contain the following:-

- Details of the optical route
- Optical budget for the route as provided by Northern Powergrid
- 'A' end and 'B' end identification
- Date of test
- Total number of splices
- Equipment details
- Fibre identification number
- Operating wavelength
- Launch Power (dB)
- Attenuation of A-B and B-A (dB)

Document Reference:-	NSP/004/124	Document Type:-	Code of Practice				
Version:-	2.0	Date of Issue:-	November 2023	Page	15	of	26

- Average attenuation (dB)
- Pass / Fail

In addition the contractor shall provide Northern Powergrid with a complete set of map sheets at 1:500 scale marked up to show the as built underground section duct route with all chambers and splice positions marked up accordingly.

3.14. Accessories and fittings

All OPGW fittings and accessories shall be tested in accordance with ENA 43-126 "*Fittings for Overhead Line Optical Cables – Part 1 OPGW*".

Document Reference:-	NSP/004/124	Document Type:-	Code of Practice				
Version:-	2.0	Date of Issue:-	November 2023	Page	16	of	26

4. References

4.1. External Documentation

Reference	Title
ENA 43-126	Fittings for Overhead Line Optical Cables – Part 1 OPGW
ENA G67	Safety in conductor stringing on Overhead transmission Lines
SMCC Guidance Notes	Earthwire replacement with one circuit alive on 132kV double Circuit Tower lines”
SMCC 006	Notes of guidance on Earth Wire replacement with one circuit live on 132kV double circuit tower lines

4.2. Internal Documentation

Reference	Title
NPS/002/024	Technical Specification for Fibre Optic Cables, Wrap, OPGW and ADSS
NSP/002/001	Guidance Document for the Installation of Fibre Optic Underground Cables
NSP/004/123	Guidance document on the installation of Fibre Optic Wrap onto Overhead Line Conductors

4.3. Amendments from Previous Version

Reference	Description
Whole Document	Document reviewed no changes required – Paul McAdoo 03/10/2023 Doc approved by email Paul Black 05/10/2023 Doc republished to grid and externally - LB 07/11/2023

Document Reference:-	NSP/004/124	Document Type:-	Code of Practice				
Version:-	2.0	Date of Issue:-	November 2023	Page	17	of	26

5. Definitions

Term	Definition
ACDs - Anti-climbing Devices	Methods of preventing unauthorised access to pole and tower tops. Usually involves loops of barbed wire.
ACSR	Aluminium Conductor Steel Reinforced
Attenuation	The reduction in optical power as a signal passes along a fibre due to dispersion, absorption and scattering. Usually expressed in decibels (dB).
Cassette	2 reels of fibre cable spooled back to back, to maximise splice spacing.
Cassette Plan	A list of cassette and/or reel lengths indicating spin points and splice locations.
De-energised	free from connection to a source of potential difference or electric Charge, and not having a potential different to that of the ground. This term only refers to current carrying parts and is not normally earth-wires unless they are insulated. Even if the circuit is De-energised it may be electrically charged through induction from nearby circuits.
Earth Bond	Bond to electrically connect equipment to ground potential for safety purposes.
Energised	Electrically connected to a source of potential difference, or electrically charged so as to have a potential different to that of the ground.
Fittings	Any hardware attached to a fibre optic cable or related to its connection to a tower, conductor or another cable.
ILM	Insertion Loss Measurement - insertion loss is the loss of signal power resulting from the insertion of a device in an optical fibre route and is usually expressed in decibels (dB).
Jumper	The loop of conductor/earth-wire formed between incoming and outgoing conductors or earth-wires at a dead-end structure.
Live Line Working	Term used to describe working condition for earth-wire installations when all adjacent phase circuits are energized.
Mid-Span Joint	A joint in the earth-wire/conductor, normally a crimped sleeve or helical wire preform, between two structures.
NBL	Nominal Breaking Load. 95% of RTS.
ODF	Optical Distribution Frame
OPGW	Optical Groundwire
Optical Budget	The optical power budget in a fibre-optic communication link is the allocation of available optical power (launched into a given fibre by a given source) among various loss-producing mechanisms such as launch coupling loss, fibre attenuation, splice losses, and connector losses, in order to ensure that adequate signal strength (optical power) is available at the receiver. In optical power budget attenuation is specified in decibels (dB).
Optical Fibre	A strand of very thin, optically pure glass that can carry digital information over long distances
OTDR	Optical time-domain reflectometer – An OTDR tester is used for testing and fault finding within fibre optic networks and fibre cables
Overhead Splice Box	A splice box designed to be mounted on the conductor or earth-wire.
Patch Lead	Short length of fibre optic cable, with a connector at each end, used to join items of equipment such as optical distribution frame and relay panel
RTS	Rated tensile strength. Calculated by adding the strengths of the individual wires making up the cable.
Shackle	U-shaped piece of metal secured with a pin or bolt across the opening.
Single-mode Fibre	An optical fibre designed to carry only a single ray (mode) of light.
Span End Clamp	A clamp designed to grip the SkyWrap™ cable at transition and termination points, and prevent it moving relative to the conductor or earth-wire.
Spinning Machine or wrapping machine	Machine used to helically wrap fibre optic cable on a conductor or earth-wire. Pulled by a tug or rope and carries a spool of WRAP.
Structure	A general expression for a tower or pole.

Document Reference:-	NSP/004/124	Document Type:-	Code of Practice				
Version:-	2.0	Date of Issue:-	November 2023	Page	18	of	26

6. Authority for Issue

6.1. CDS Assurance

I sign to confirm that I have completed and checked this document and I am satisfied with its content and submit it for approval and authorisation.

		Date
Liz Beat	Governance Administrator	07/11/2023

6.2. Author

I sign to confirm that I have completed and checked this document and I am satisfied with its content and submit it for approval and authorisation.

Review Period - This document should be reviewed within the following time period;

Standard CDS review of 3 years?	Non Standard Review Period & Reason	
Yes	Period: N/A	Reason: N/A
Should this document be displayed on the Northern Powergrid external website?		Yes
		Date
Ged Hammel	Senior Policy & Standards Engineer	22/11/2019

6.3. Technical Assurance

I sign to confirm that I am satisfied with all aspects of the content and preparation of this document and submit it for approval and authorisation.

		Date
Steven Salkeld	Policy & Standards Engineer	21/11/2019
Paul McAdoo	Lead Policy & Standards Engineer	03/10/2023

6.4. Authorisation

Authorisation is granted for publication of this document.

		Date
Paul Black	Head of System Engineering	05/10/2023

Document Reference:-	NSP/004/124	Document Type:-	Code of Practice				
Version:-	2.0	Date of Issue:-	November 2023	Page	19	of	26

Appendix 1 – OPGW Section Structure – (Tails down to Splice Box)

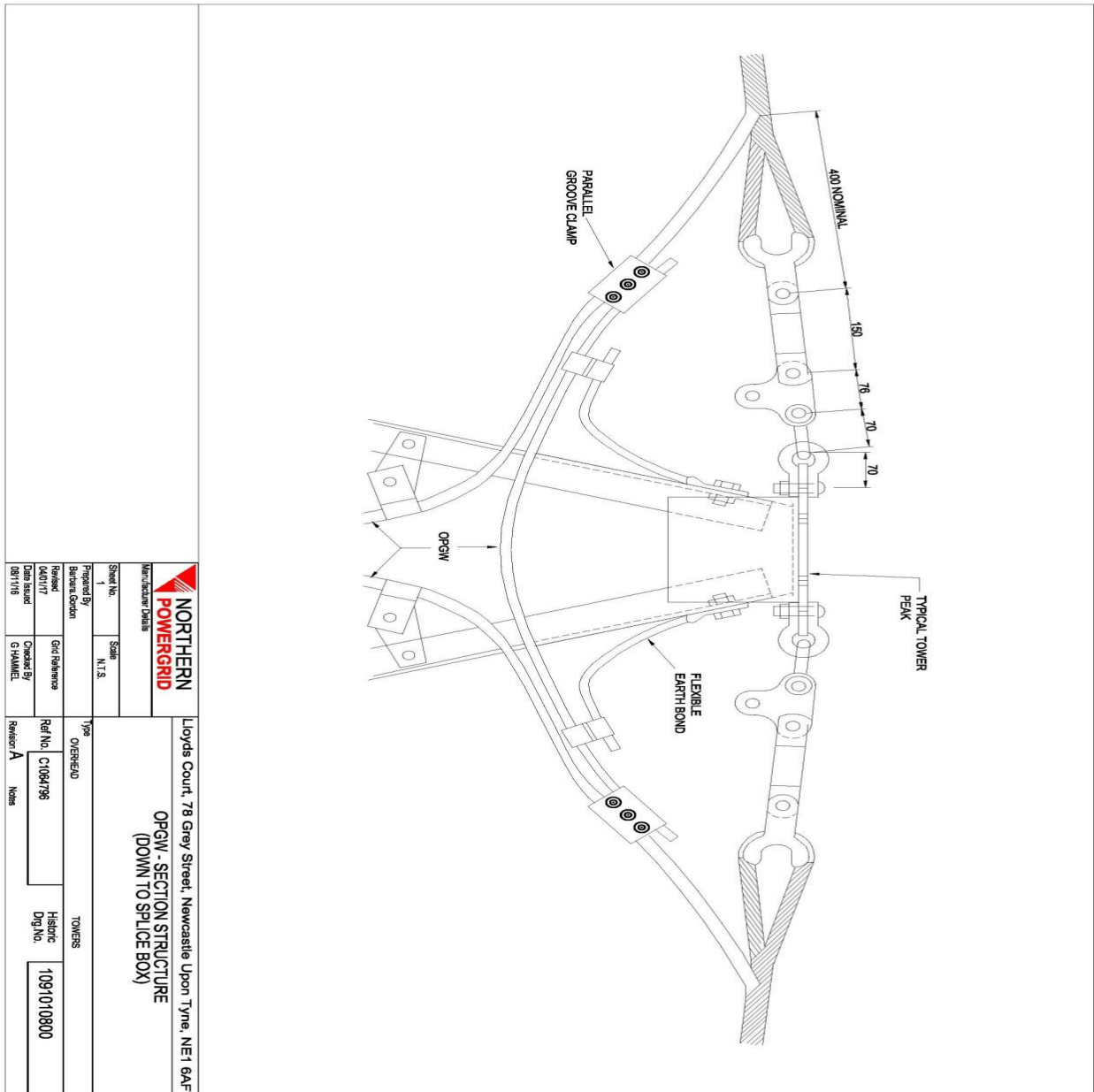

Document Reference:- NSP/004/124		Document Type:- Code of Practice	
Version:- 2.0	Date of Issue:- November 2023	Page 20	of 26

Appendix 2 – OPGW Section Splice Arrangement

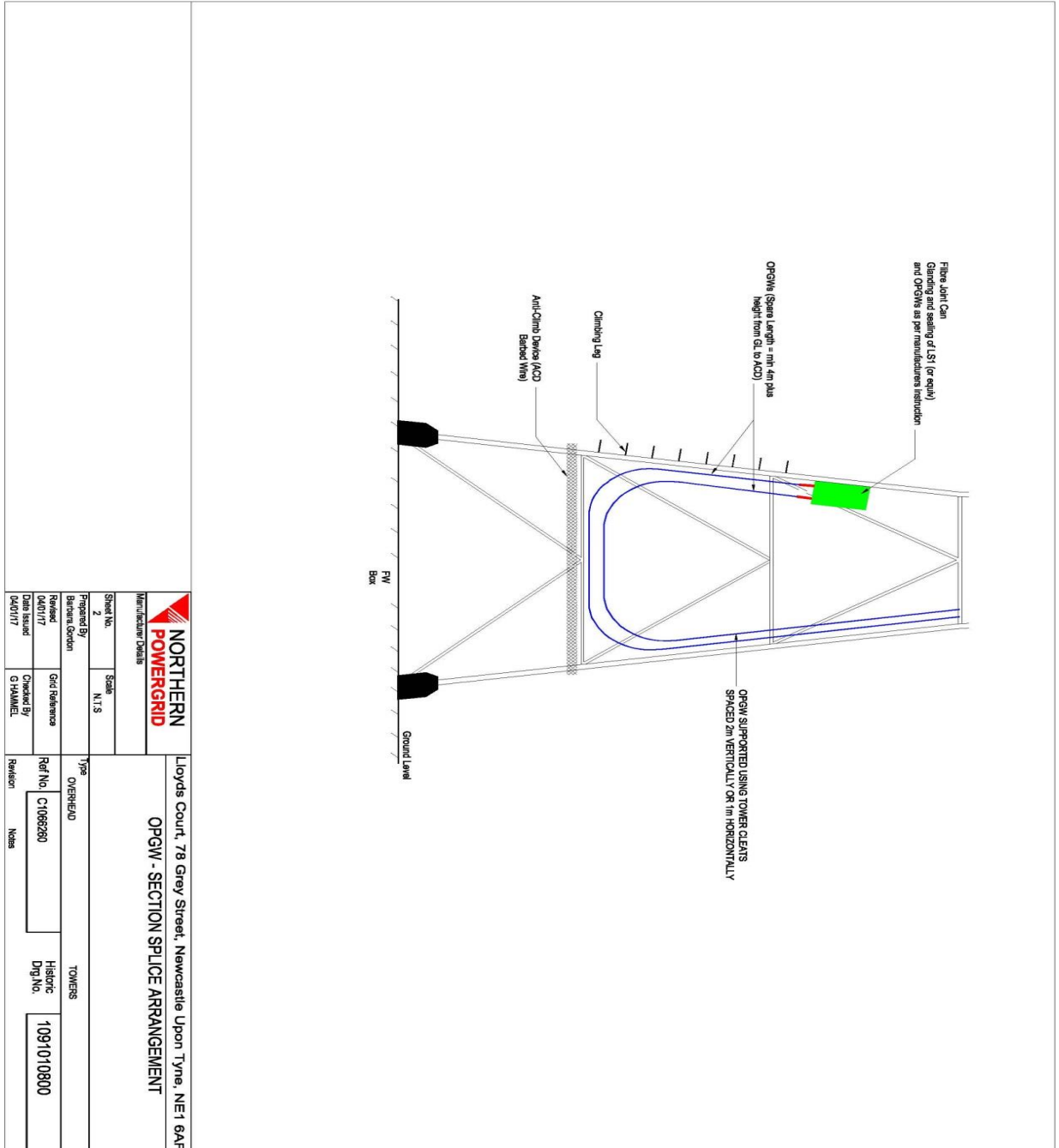

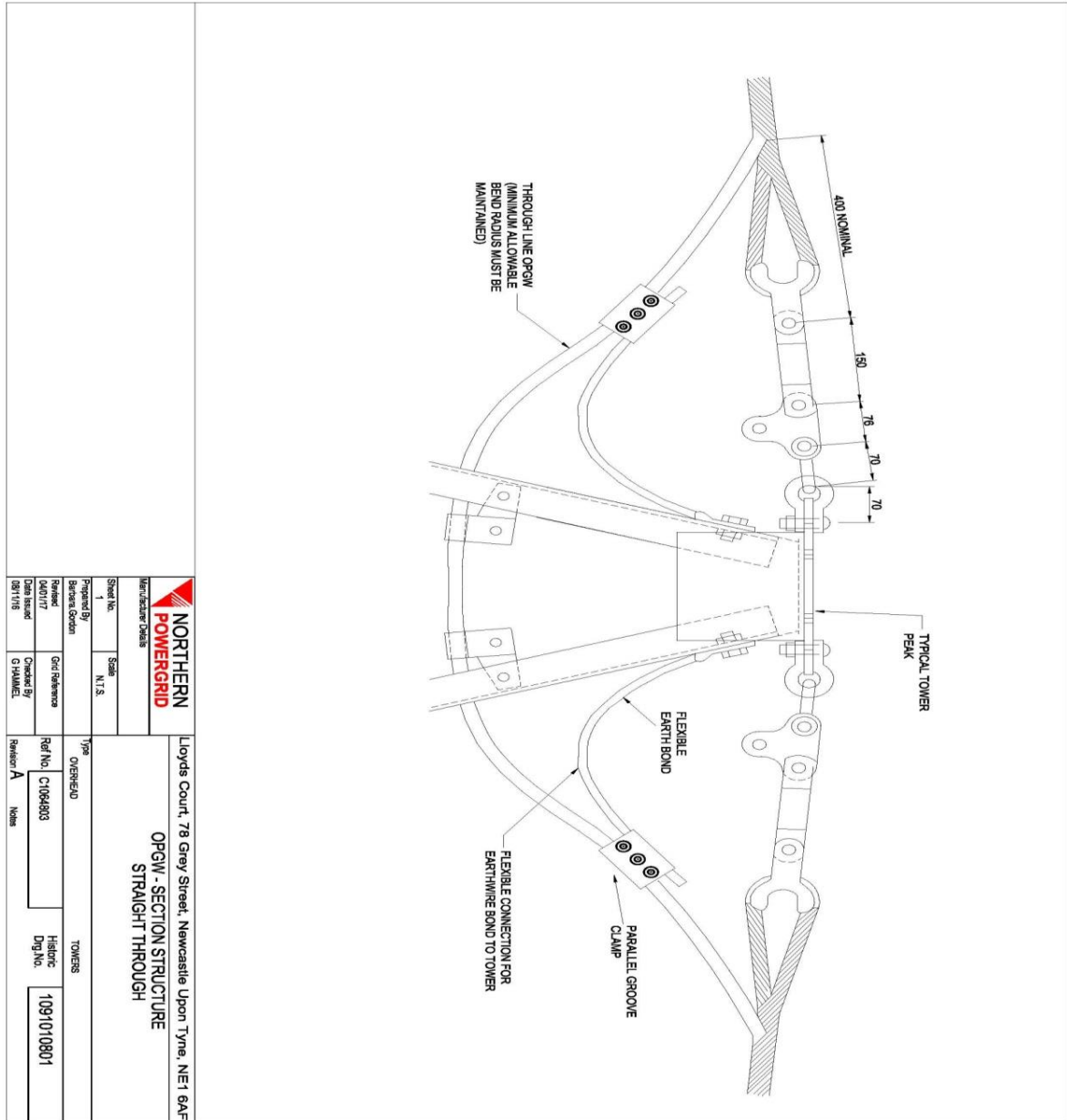

Document Reference:- NSP/004/124		Document Type:- Code of Practice	
Version:- 2.0	Date of Issue:- November 2023	Page 21	of 26

Appendix 3 – OPGW Section Structure – (Straight Through Arrangement)

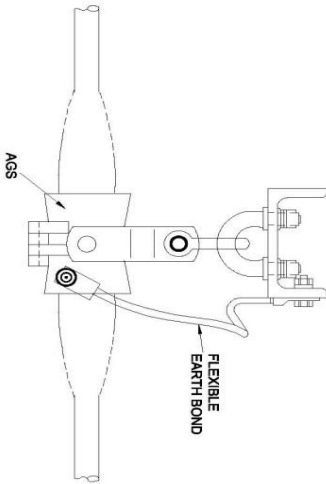
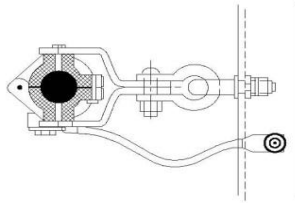

Document Reference:-	NSP/004/124	Document Type:-	Code of Practice				
Version:-	2.0	Date of Issue:-	November 2023	Page	22	of	26

Appendix 4 – OPGW Intermediate Structure – (Suspension Arrangement)

		
Sheet No. 1 Prepared By: [Name] Reviewed: [Name] Date Issued: 08/11/18	Scale: N.T.S. Checked By: C.F.H.M.H.L.T.	Type: OVERHEAD Ref No.: C1064835 Revision: A
Lloyds Court, 78 Grey Street, Newcastle Upon Tyne, NE1 6AF OPGW - SUSPENSION STRUCTURE		
		TOWERS Historic Dwg. No.: 1091010802

Document Reference:-	NSP/004/124	Document Type:-	Code of Practice				
Version:-	2.0	Date of Issue:-	November 2023	Page	23	of	26

Appendix 5 – OPGW Terminal Structure

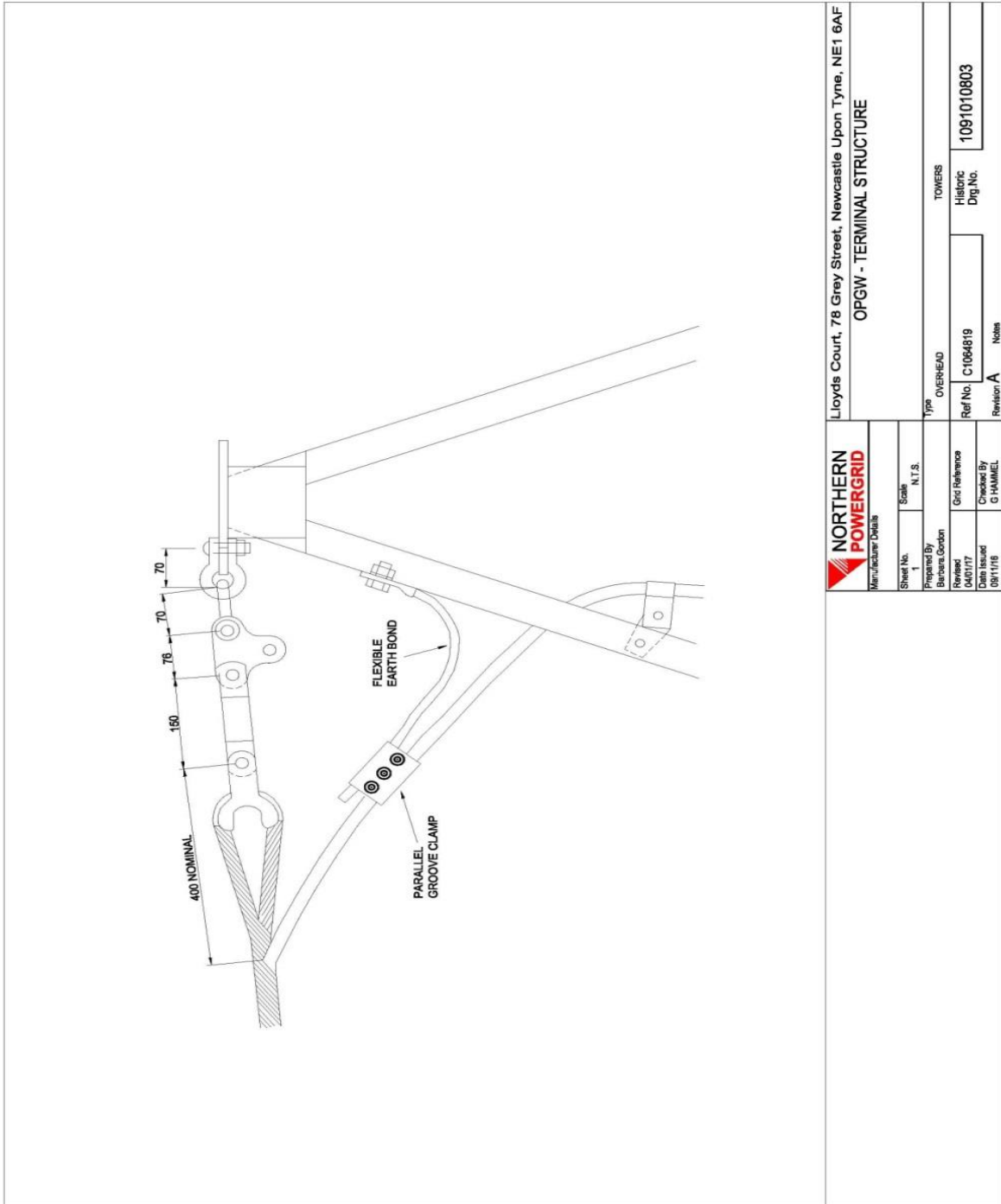

Document Reference:-	NSP/004/124	Document Type:-	Code of Practice				
Version:-	2.0	Date of Issue:-	November 2023	Page	24	of	26

Appendix 6 – OPGW Terminal Structure with Underground Splice Connection

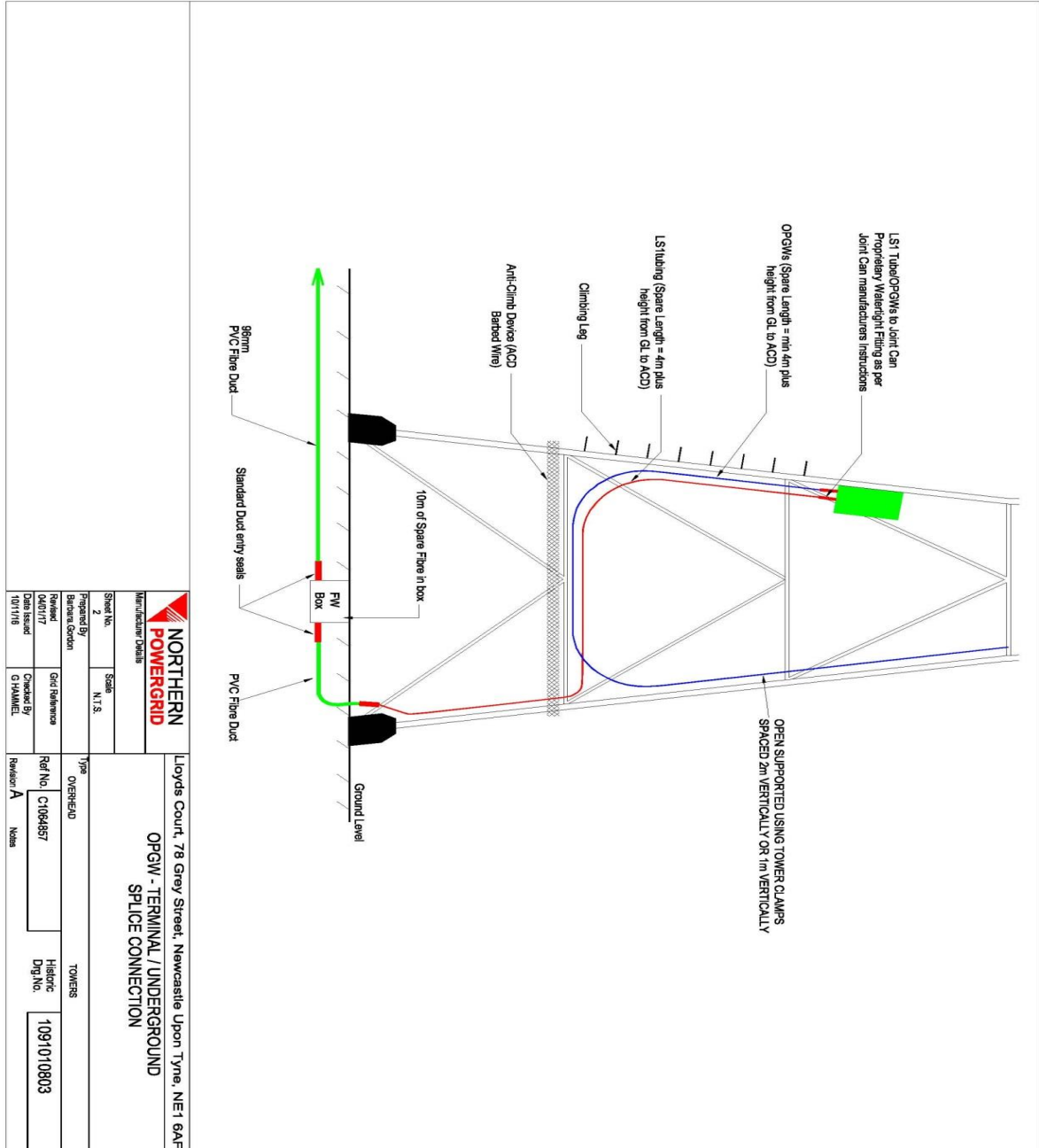

Document Reference:-	NSP/004/124	Document Type:-	Code of Practice				
Version:-	2.0	Date of Issue:-	November 2023	Page	25	of	26

Appendix 7 – OPGW Tee-off Splice Arrangement

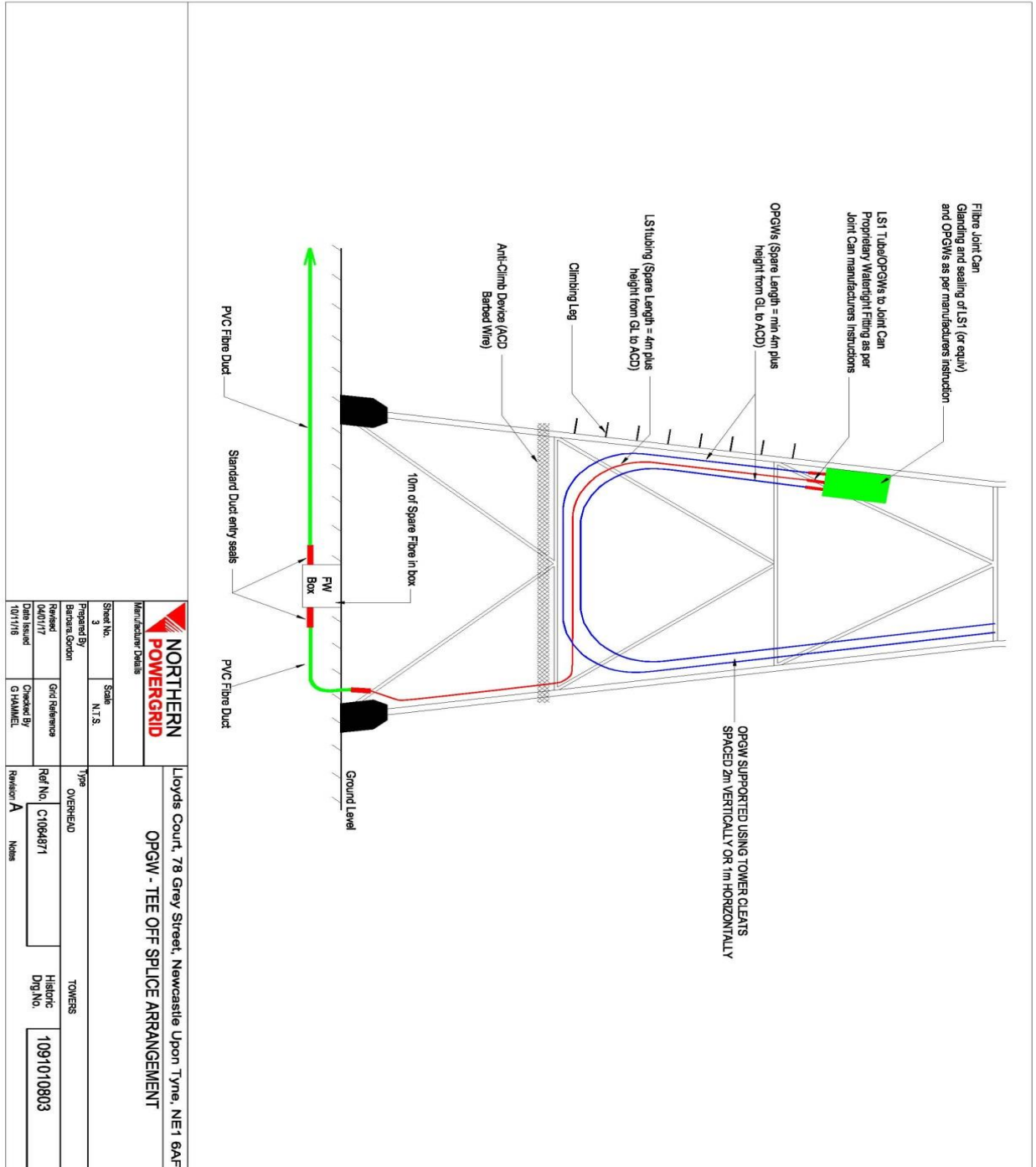

Document Reference:-	NSP/004/124	Document Type:-	Code of Practice				
Version:-	2.0	Date of Issue:-	November 2023	Page	26	of	26

Appendix 8 – Typical Tower Cleat

